

Small- μ Theorems with Frequency-Dependent Uncertainty Bounds*

A. L. Tits[†]

Department of Electrical Engineering and
Institute for Systems Research
University of Maryland
College Park, MD 20742
Phone: +1 301 405-3669
Fax: +1 301 405-6707
Internet: andre@isr.umd.edu

V. Balakrishnan

School of Electrical and
Computer Engineering
Purdue University
West Lafayette, IN 47907-1285
Phone: +1 765 494-0728
Fax: +1 765 494-3371
Internet: ragu@ecn.purdue.edu

Abstract

We present conditions, some necessary and some sufficient, valid under weak assumptions, for robust stability and uniform robust stability of uncertain linear time-invariant systems with linear time-invariant uncertainties that are block-diagonal, with known frequency-dependent norm bounds on the diagonal blocks. Small- μ theorems with frequency-independent uncertainty bounds are recovered as special cases.

Keywords: Robust stability, Uncertain systems, Robust control, Small- μ theorem, Frequency-dependent uncertainty bounds.

*This research was in part supported by NSF's Engineering Research Center No. NSFD-CDR-88-03012, and in part by the Office of Naval Research under contract No. N00014-97-1-0640.

[†]Corresponding author.

1 Introduction

A popular paradigm for modeling control systems with uncertainties is illustrated in Figure 1. Here P is the transfer function of a stable linear system, and Δ is a stable operator that represents the “uncertainties” that arise from various sources such as modeling errors, neglected or unmodeled dynamics or parameters, etc. Often, the uncertainty Δ is assumed to possess various additional properties. Common examples are that Δ is structured (i.e., diagonal or block-diagonal), that it is linear time-invariant or real-constant etc. Such control system models have found wide acceptance in robust control; see for example [D, S, PD, L, ZDG]. We will henceforth refer to the system in Figure 1 as the P - Δ interconnection, and denote it by $\mathcal{I}(P, \Delta)$.

The Small- μ Theorem is the foundation of the structured singular value approach towards assessing the stability of systems affected by structured uncertainties. Specifically, the theorem gives a necessary and sufficient condition on the “ μ -norm” of the plant transfer function P for $\mathcal{I}(P, \Delta)$ to be stable for all structured $\Delta \in \mathbf{H}_\infty$ of a given maximum size (\mathbf{H}_∞ -norm). Various versions of the small- μ theorem exist in the literature, and it was shown in [TF] that some commonly quoted versions of this theorem are in fact incorrect.

The situation is even less clear when the norm-bound on Δ is frequency-dependent. To the authors’ knowledge, no formal extension of the small- μ theorem to this case is available in the open literature. Proofs informally mentioned within the research community are usually based on the construction, for each uncertainty block, of an \mathbf{H}_∞ function, invertible in \mathbf{H}_∞ , whose magnitude on the unit circle (in the discrete-time case) is equal to the given uncertainty bound $w_i(z)$. Such proofs assume that the uncertainty bounds possess some regularity properties (implying their boundedness), and are bounded away from zero. In this article, we first formally state and prove such a small- μ theorem (Theorem 1).

Stability of $\mathcal{I}(P, \Delta)$ for all Δ in the uncertainty set of interest is usually referred to as “robust stability.” Another concept that has received scant attention in the literature is that of “uniform robust stability.” $\mathcal{I}(P, \Delta)$ is uniformly robustly stable over a given uncertainty set if not only the transfer matrix of interest remains in \mathbf{H}_∞ as Δ ranges over that set, but furthermore its norm remains bounded by a quantity independent of Δ .

The major part of the article is devoted to deriving conditions for robust stability and uniform robust stability of the P - Δ interconnection, when the boundedness and regularity assumptions on the uncertainty bounds are relaxed. Note that, in particular, the boundedness assumption on the w_i s may be overly restrictive, as often the uncertainty is modeled

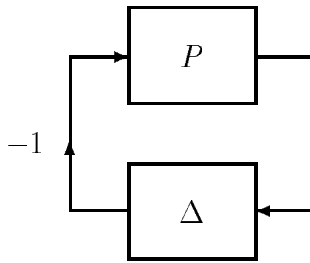

Figure 1: The P - Δ interconnection modeling an uncertain system.

as being arbitrarily large at high frequency. We first show that if mere stability rather than uniform stability is sought, then a sufficient “small- μ ” condition holds without any boundedness or regularity assumptions on the w_i s. We also derive a necessary condition for uniform robust stability where the assumption that the w_i s are bounded away from zero is relaxed; however, certain regularity conditions on how fast the w_i s can approach zero become necessary in order to have a nontrivial set of uncertainties. Finally, we show that for certain uncertainty models, a necessary and sufficient condition for robust stability can be obtained, without any boundedness assumption on the w_i s. Known small- μ theorems with frequency-independent uncertainty bounds are recovered as special cases and stated as Corollaries 1 through 4.

2 Preliminaries

We will focus our attention for the most part on discrete-time systems, as the technical details become somewhat simpler here; we discuss continuous-time systems briefly in §5. Let \mathbb{R}_+ be the set of nonnegative real numbers. Let \mathbb{D} denote the closed unit disk $\{z : z \in \mathbb{C}, |z| \leq 1\}$, $\mathbb{D}^c = \mathbb{C} \setminus \mathbb{D}$ its complement, $\overline{\mathbb{D}^c}$ the closure of \mathbb{D}^c , and $\partial\mathbb{D}$ the unit circle $\{z : z \in \mathbb{C}, |z| = 1\}$. Given a matrix $M \in \mathbb{C}^{n \times n}$, let M^* denote its complex conjugate transpose, $\overline{\sigma}(M)$ its largest singular value, and $\underline{\sigma}(M)$ its smallest singular value. $\mathbf{H}_\infty(\mathbb{D}^c)$ denotes the set of functions that are bounded and analytic in \mathbb{D}^c . For compactness of notation, we will also use $\mathbf{H}_\infty(\mathbb{D}^c)$ to denote matrix-valued functions whose entries are in $\mathbf{H}_\infty(\mathbb{D}^c)$. Finally, the \mathbf{H}_∞ norm of $H \in \mathbf{H}_\infty(\mathbb{D}^c)$ is denoted $\|H\|_\infty$, and defined as

$$\|H\|_\infty = \sup_{z \in \mathbb{D}^c} \overline{\sigma}(H(z)).$$

Let R, S and F be nonnegative integers, not all zero, and let $n, r_1, \dots, r_R, s_1, \dots, s_S$ and f_1, \dots, f_F be positive integers with $n = \sum r_i + \sum s_i + \sum f_i$. Define $n_r = \sum r_i$ and $n_c = \sum s_i + \sum f_i$. Let $\mathbf{\Gamma}_r$ be the subspace of real $n_r \times n_r$ matrices defined by

$$\mathbf{\Gamma}_r = \{\text{diag}(\gamma_1 I_{r_1}, \dots, \gamma_R I_{r_R}) : \gamma_i \in \mathbb{R}\}, \quad (1)$$

let $\mathbf{\Gamma}_c$ be the subspace of complex $n_c \times n_c$ matrices defined by

$$\mathbf{\Gamma}_c = \{\text{diag}(\gamma_1 I_{s_1}, \dots, \gamma_S I_{s_S}, \Gamma_1, \dots, \Gamma_F) : \gamma_i \in \mathbb{C}, \Gamma_i \in \mathbb{C}^{f_i \times f_i}\}, \quad (2)$$

and let

$$\mathbf{\Gamma} = \{\text{diag}(\Gamma_r, \Gamma_c) : \Gamma_r \in \mathbf{\Gamma}_r, \Gamma_c \in \mathbf{\Gamma}_c\}, \quad (3)$$

and

$$\mathbf{B}\Gamma = \{\Gamma \in \Gamma : \bar{\sigma}(\Gamma) \leq 1\}.$$

The structured singular value of a matrix $M \in \mathbb{C}^{n \times n}$ with respect to a block structure Γ is defined to be $\mu(M) = 0$ if there is no $\Gamma \in \Gamma$ such that $\det(I + \Gamma M) = 0$, and

$$\mu(M) = \left(\min_{\Gamma \in \Gamma} \{\bar{\sigma}(\Gamma) : \det(I + \Gamma M) = 0\} \right)^{-1}$$

otherwise. The description above corresponds to the so-called ‘‘standard mixed- μ ’’ framework. The quantity μ plays a central role in the stability analysis of systems with real and complex structured perturbations; see, e.g., [ZD, §8.12].

We will make use of various sets of functions in $\mathbf{H}_\infty(\mathbb{D}^c)$ that will be assumed to have continuous extension on $\overline{\mathbb{D}^c}$.¹ In that context, we will often abuse notation and use the same symbol for a function in $\mathbf{H}_\infty(\mathbb{D}^c)$ and the corresponding extension. Let $\mathbf{\Delta}_c$ be defined by

$$\mathbf{\Delta}_c = \{\Delta_c \in \mathbf{H}_\infty(\mathbb{D}^c) : \Delta_c(z) \in \Gamma_c \forall z \in \mathbb{D}^c, \Delta_c \text{ has a continuous extension on } \overline{\mathbb{D}^c}\},$$

and let $\mathbf{\Delta}$ be defined by

$$\mathbf{\Delta} = \{\Delta : \Delta = \text{diag}(\Delta_r, \Delta_c), \Delta_r \in \Gamma_r, \Delta_c \in \mathbf{\Delta}_c\}. \quad (4)$$

In this paper, our concern is to extend the standard mixed- μ analysis to the case when the complex uncertainties have frequency-dependent upper bounds. To this end, define

$$\mathcal{W} = \left\{ \begin{array}{l} W = \text{diag}(\rho_1 I_{r_1}, \dots, \rho_R I_{r_R}, w_1 I_{s_1}, \dots, w_S I_{s_S}, w_{S+1} I_{f_1}, \dots, w_{S+F} I_{f_F}) \text{ for} \\ W : \text{some nonnegative real numbers } \rho_i, i = 1, \dots, R \text{ and some functions} \\ w_i : \partial\mathbb{D} \rightarrow \mathbb{R}_+, i = 1, \dots, (S + F) \end{array} \right\}. \quad (5)$$

Of special interest are those W that are *conjugate-symmetric*, i.e., that satisfy

$$W(z^*) = W(z) \text{ for all } z \in \partial\mathbb{D}.$$

Given $W \in \mathcal{W}$, define

$$\mathbf{B}_W \mathbf{\Delta} = \{\Delta \in \mathbf{\Delta} : \Delta(z)^* \Delta(z) \leq W(z)^2 \text{ for all } z \in \partial\mathbb{D}\}. \quad (6)$$

For future use, also define, for $W \in \mathcal{W}$,

$$\mathbf{B}_W \mathbf{R}\mathbf{\Delta} = \{\Delta \in \mathbf{B}_W \mathbf{\Delta} : \Delta \text{ is real on the real axis}\},$$

¹In [T], a small- μ theorem is obtained, in the case of constant scaling, without such assumption on P and Δ .

and

$$\mathbf{B}_W \mathbf{R} \mathbf{R} \mathbf{\Delta} = \{\Delta \in \mathbf{B}_W \mathbf{\Delta} : \Delta \text{ is real-rational}\},$$

as well as (corresponding to $W(z) = I$ for all $z \in \partial\mathbb{D}$),

$$\mathbf{B} \mathbf{\Delta} = \{\Delta \in \mathbf{\Delta} : \bar{\sigma}(\Delta(z)) \leq 1 \forall z \in \partial\mathbb{D}\},$$

$$\mathbf{B} \mathbf{R} \mathbf{\Delta} = \{\Delta \in \mathbf{B} \mathbf{\Delta} : \Delta \text{ is real on the real axis}\},$$

and

$$\mathbf{B} \mathbf{R} \mathbf{R} \mathbf{\Delta} = \{\Delta \in \mathbf{B} \mathbf{\Delta} : \Delta \text{ is real-rational}\}.$$

Consider now $\mathcal{I}(P, \Delta)$ where $P \in \mathcal{P}$, with

$$\mathcal{P} = \{P \in \mathbf{H}_\infty(\mathbb{D}^c) : P \text{ has a continuous extension on } \overline{\mathbb{D}^c}\},$$

and with Δ assumed to lie in $\mathbf{\Delta}$. For every such P and Δ such that $\mathcal{I}(P, \Delta)$ is well-posed,² we will denote by G_Δ the following transfer function, associated with $\mathcal{I}(P, \Delta)$:

$$G_\Delta = \begin{pmatrix} (I + \Delta P)^{-1} & \Delta(I + P\Delta)^{-1} \\ P(I + \Delta P)^{-1} & (I + P\Delta)^{-1} \end{pmatrix}. \quad (7)$$

Given $\mathbf{S} \subseteq \mathbf{\Delta}$, if G_Δ is well defined and belongs to $\mathbf{H}_\infty(\mathbb{D}^c)$ for all $\Delta \in \mathbf{S}$ or, equivalently, if $(I + \Delta P)$ is invertible in $\mathbf{H}_\infty(\mathbb{D}^c)$ for all such Δ , we will say that $\mathcal{I}(P, \mathbf{S})$ is *robustly stable*. If $\mathcal{I}(P, \mathbf{S})$ is robustly stable, and if moreover

$$\sup_{\Delta \in \mathbf{S}} \|G_\Delta\|_\infty < \infty, \quad (8)$$

we will say that $\mathcal{I}(P, \mathbf{S})$ is *uniformly robustly stable*. The second definition is inspired from [KGP].

Remark: Whenever W is bounded, (8) is clearly equivalent to

$$\sup_{\Delta \in \mathbf{S}} \|(I + \Delta P)^{-1}\|_\infty < \infty. \quad (9)$$

When W is unbounded, however, (9) is weaker than (8). In such a case, it is not clear that (8) is the “right” definition for uniform robust stability. Indeed, the question of which nodes in the block-diagram of Figure 1 are “physical” depends on the uncertainty model from which this block-diagram is derived (additive, multiplicative, etc.). Still, most results derived below remain true when (8) is replaced with (9). When this is not the case, it is pointed out. \diamond

²This simply means that the equations describing the interconnection have a unique solution.

When $W(z) = I_n$ for all $z \in \mathbb{D}^c$, the situation considered here is the standard complex- μ problem, and a number of precise mathematical statements have been made relating robust stability, uniform robust stability and μ in this case; see [TF] for example. For general W , however, no such statements can be found in the literature. The objective of this paper is to explore this issue.

We first note that under some assumptions on W , we can provide necessary and sufficient conditions for uniform robust stability of the P - Δ interconnection by appealing to standard μ results. We have the following theorem.

Theorem 1 *Let $P \in \mathcal{P}$ and let*

$$W = \text{diag}(\rho_1 I_{r_1}, \dots, \rho_R I_{r_R}, w_1 I_{s_1}, \dots, w_S I_{s_S}, w_{S+1} I_{f_1}, \dots, w_{S+F} I_{f_F}) \in \mathcal{W}. \quad (10)$$

Suppose for each $i = 1, \dots, (S+F)$, $w_i : \partial\mathbb{D} \rightarrow \mathbb{R}_+$ is continuously differentiable, and nowhere vanishing. Then, $\mathcal{I}(P, \mathbf{B}_W \Delta)$ is uniformly robustly stable if and only if

$$\sup_{z \in \partial\mathbb{D}} \mu(W(z)P(z)) < 1. \quad (11)$$

In addition, if W is conjugate-symmetric, then $\mathcal{I}(P, \mathbf{B}_W \mathbf{R} \Delta)$ is uniformly robustly stable if and only if (11) holds. Finally, if condition (11) does not hold, then $\mathcal{I}(P, \mathbf{B}_W \Delta)$ is not even robustly stable.³

Proof: The main step in the proof is to apply Lemma 6 (in Appendix A) to construct analytic functions $\phi_i : \mathbb{D}^c \rightarrow \mathbb{C}$, $i = 1, \dots, (S+F)$, with $\phi_i, \phi_i^{-1} \in \mathbf{H}_\infty(\mathbb{D}^c)$, satisfying $|\phi_i(rz)| \rightarrow w_i(z)$ as $r \downarrow 1$ for every $z \in \partial\mathbb{D}$. Let

$$\Phi = \text{diag}(\rho_1 I_{r_1}, \dots, \rho_R I_{r_R}, \phi_1 I_{s_1}, \dots, \phi_S I_{s_S}, \phi_{S+1} I_{f_1}, \dots, \phi_{S+F} I_{f_F}).$$

Then, with $\tilde{P} = \Phi P$, condition (11) is equivalent to the condition that

$$\sup_{z \in \partial\mathbb{D}} \mu(\tilde{P}(z)) < 1. \quad (12)$$

A standard result in μ analysis⁴ states that this condition is equivalent to $\mathcal{I}(\tilde{P}, \mathbf{B} \Delta)$ being robustly stable, and $\sup_{\tilde{\Delta} \in \mathbf{B} \Delta} \|(I + \tilde{\Delta} \tilde{P})^{-1}\|_\infty < \infty$. Moreover, if condition (12) does not hold, then $\mathcal{I}(P, \Delta)$ is unstable for some $\tilde{\Delta} \in \mathbf{B} \Delta$.

³However, $\mathcal{I}(P, \mathbf{B}_W \mathbf{R} \Delta)$ can still be robustly stable, even when P is real-rational, and even when $W(z) = I$ for all $z \in \partial\mathbb{D}$: see [TF].

⁴In particular, this result is alluded to at the end of [TF]. It is obtained in this paper at the end of §4 (Corollary 1) as a special case of our general result, Theorem 4, proved from first principles.

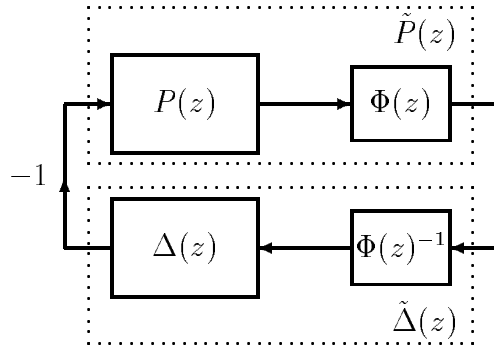

Figure 2: The \tilde{P} - $\tilde{\Delta}$ interconnection. $\mathcal{I}(P, \Delta)$ is stable if and only if $\mathcal{I}(\tilde{P}, \tilde{\Delta})$ is.

Now, defining $\Delta = \tilde{\Delta}\Phi$, we see that $\tilde{\Delta} \in \mathbf{B}\Delta$ if and only if $\Delta \in \mathbf{B}_W\Delta$. Moreover, $\mathcal{I}(\tilde{P}, \tilde{\Delta})$ is stable if and only if $\mathcal{I}(P, \Delta)$ is stable (see Figure 2). Also note that $\Delta P = \tilde{\Delta}\tilde{P}$. Therefore, we conclude that condition (11) is equivalent to $\mathcal{I}(P, \mathbf{B}_W\Delta)$ being robustly stable, and $\sup_{\Delta \in \mathbf{B}_W\Delta} \|(I + \Delta P)^{-1}\|_\infty < \infty$. Moreover, if condition (11) does not hold, then $\mathcal{I}(P, \Delta)$ is unstable for some $\Delta \in \mathbf{B}_W\Delta$. The claim concerning $\mathcal{I}(P, \mathbf{B}_W\mathbf{R}\Delta)$ follows similarly, in view of the fact that, if W is conjugate-symmetric, Φ is real on the real axis. This completes the proof. \blacksquare

Clearly, condition (11) is sufficient for uniform robust stability of $\mathcal{I}(P, \mathbf{B}_W\mathbf{R}\mathbf{R}\Delta)$ as well. However, the proof of Theorem 1 cannot be easily modified to address the question of whether condition (11) is necessary for uniform robust stability of $\mathcal{I}(P, \mathbf{B}_W\mathbf{R}\mathbf{R}\Delta)$. Moreover, the uniform robust stability condition is stated in Theorem 1 under fairly strong assumptions on w_i . In particular, it is required that w_i be bounded, which is unnatural as often uncertainty bounds are known reliably only over certain frequency ‘‘bands’’. (This is specially true in the continuous-time case, where the uncertainty is typically modeled as being arbitrarily large at high frequency.) In the rest of the paper, we explore the possibility of addressing some of these issues. A direct approach becomes necessary however.

3 Irreducible representation of uncertainty balls

It is in general not necessary that $\mu(W(z)P(z)) < 1$ for all $z \in \partial\mathbb{D}$ in order for $\mathcal{I}(P, \mathbf{B}_W\Delta)$ to be robustly stable: consider the trivial case where some w_i is discontinuous at some point and takes a large value there but is small everywhere else. A less trivial situation in which $\mathcal{I}(P, \mathbf{B}_W\Delta)$ can be robustly stable even though (12) is violated arises when for some i , w_i is nonzero, but there is no nonzero function in $\mathbf{H}_\infty(\mathbb{D}^c)$ whose magnitude on $\partial\mathbb{D}$ lies below w_i . Finally, it is clear that, unless W is conjugate-symmetric, $\mathcal{I}(P, \mathbf{B}_W\mathbf{R}\Delta)$ and $\mathcal{I}(P, \mathbf{B}_W\mathbf{R}\mathbf{R}\Delta)$ can be robustly stable even when (12) does not hold. These observations motivate the following definitions.

We say that

$$W = \text{diag}(\rho_1 I_{r_1}, \dots, \rho_R I_{r_R}, w_1 I_{s_1}, \dots, w_S I_{s_S}, w_{S+1} I_{f_1}, \dots, w_{S+F} I_{f_F}) \in \mathcal{W} \quad (13)$$

is $\mathbf{H}_\infty(\mathbb{D}^c)$ -irreducible if (i) w_i , $i = 1, \dots, (S + F)$ is lower semicontinuous, and (ii) for every w_i , $i \in \{1, \dots, (S + F)\}$ that is not identically zero, the corresponding uncertainty sub-ball contains a nonzero element, i.e., for $i = 1, \dots, (S + F)$, there exists some nonzero

$\Delta_{c,i} \in \mathbf{H}_\infty(\mathbb{D}^c)$, continuous on $\overline{\mathbb{D}^c}$, such that

$$\Delta_{c,i}(z)^* \Delta_{c,i}(z) \leq w_i(z)^2 I \quad \forall z \in \partial\mathbb{D}. \quad (14)$$

We say that W is *real $\mathbf{H}_\infty(\mathbb{D}^c)$ -irreducible* if it is $\mathbf{H}_\infty(\mathbb{D}^c)$ -irreducible, and W is conjugate-symmetric. We say that it is *real-rational $\mathbf{H}_\infty(\mathbb{D}^c)$ -irreducible* if it is real $\mathbf{H}_\infty(\mathbb{D}^c)$ -irreducible, and for every w_i that is not identically zero, there exists a nonzero real-rational $\Delta_{c,i}$ such that (14) holds.

Remark: When the w_i s are lower semicontinuous, $\mathbf{H}_\infty(\mathbb{D}^c)$ -irreducibility of W reduces to the following question: Given $w_i : \partial\mathbb{D} \rightarrow \mathbb{R}_+$, lower semicontinuous, does there exist a nonzero $\delta \in \mathbf{H}_\infty(\mathbb{D}^c)$, with a continuous extension on $\overline{\mathbb{D}^c}$, whose magnitude on the unit circle lies under w_i ? The answer turns out to be “yes” if w_i vanishes nowhere on $\partial\mathbb{D}$. And, in cases when $w_i(z_0) = 0$ for some $z_0 \in \partial\mathbb{D}$, the answer depends on how “fast” w_i approaches zero as z approaches z_0 . More specifically, w_i is required to satisfy a log-integrability condition; in such a case, δ can always be picked to be real on the real axis, see Lemma 7 (in Appendix A). In the case when δ is required to be rational as well, $w_i(z)$ has to be bounded below by a function of the form $k|z - z_0|^{-2N}$, around z_0 , for some integer N and some $k > 0$. \diamond

Conditions for robust stability and uniform robust stability of $\mathcal{I}(P, \mathbf{B}_W \mathbf{\Delta})$ will be stated in terms of bounds W that are $\mathbf{H}_\infty(\mathbb{D}^c)$ -irreducible, real $\mathbf{H}_\infty(\mathbb{D}^c)$ -irreducible, or real-rational $\mathbf{H}_\infty(\mathbb{D}^c)$ -irreducible. This incurs no loss of generality, as we show next.

Let W of the form (13). Corresponding to every w_i , let \underline{w}_i be the lower envelope of w_i , i.e., let it be such that its epigraph is the closure of the epigraph of w_i . Then, define

$$\tilde{W} = \text{diag}(\rho_1 I_{r_1}, \dots, \rho_R I_{r_R}, \tilde{w}_1 I_{s_1}, \dots, \tilde{w}_S I_{s_S}, \tilde{w}_{S+1} I_{f_1}, \dots, \tilde{w}_{S+F} I_{f_F}), \quad (15)$$

where

$$\tilde{w}_i = \begin{cases} 0 & \text{if there exists no nonzero } \Delta_{c,i} \in \mathbf{H}_\infty(\mathbb{D}^c) \text{ such that (14) holds,} \\ \underline{w}_i & \text{otherwise.} \end{cases}$$

Next, define

$$\hat{W} = \text{diag}(\rho_1 I_{r_1}, \dots, \rho_R I_{r_R}, \hat{w}_1 I_{s_1}, \dots, \hat{w}_S I_{s_S}, \hat{w}_{S+1} I_{f_1}, \dots, \hat{w}_{S+F} I_{f_F}), \quad (16)$$

where

$$\hat{w}_i(z) = \min\{\tilde{w}_i(z), \tilde{w}_i(z^*)\}, \quad z \in \partial\mathbb{D}.$$

Finally, define

$$W^\dagger = \text{diag}(\rho_1 I_{r_1}, \dots, \rho_R I_{r_R}, w_1^\dagger I_{s_1}, \dots, w_S^\dagger I_{s_S}, w_{S+1}^\dagger I_{f_1}, \dots, w_{S+F}^\dagger I_{f_F}), \quad (17)$$

where

$$w_i^\dagger = \begin{cases} 0 & \text{if there exists no nonzero } \Delta_{c,i} \in \mathbf{H}_\infty(\mathbb{D}^c), \text{ real-rational, that (14) holds,} \\ \hat{w}_i & \text{otherwise.} \end{cases}$$

It is readily verified that \tilde{W} , \hat{W} , and W^\dagger are $\mathbf{H}_\infty(\mathbb{D}^c)$ -irreducible, real $\mathbf{H}_\infty(\mathbb{D}^c)$ -irreducible, and real-rational $\mathbf{H}_\infty(\mathbb{D}^c)$ -irreducible, respectively; note in particular that for each i , \underline{w}_i is lower semicontinuous.

Then, we have the following result.

Proposition 1 *Let $W \in \mathcal{W}$. Then, $\mathbf{B}_{\tilde{W}}\Delta = \mathbf{B}_W\Delta$, $\mathbf{B}_{\hat{W}}\mathbf{R}\Delta = \mathbf{B}_W\mathbf{R}\Delta$, $\mathbf{B}_{W^\dagger}\mathbf{R}\mathbf{R}\Delta = \mathbf{B}_W\mathbf{R}\mathbf{R}\Delta$.*

Proof: Suppose $\Delta \in \mathbf{B}_W\Delta$. With W as in (10), we have

$$\Delta_r^* \Delta_r \leq \text{diag}(\rho_1^2 I_{r_1}, \dots, \rho_R^2 I_{r_R}), \quad \Delta_{c,i}(z)^* \Delta_{c,i}(z) \leq w_i(z)^2 I \quad \forall z \in \partial\mathbb{D}, \quad i = 1, \dots, S + F, \quad (18)$$

where $\Delta_{c,i}$ is the i th diagonal block of Δ_c . We show that

$$\Delta_{c,i}(z)^* \Delta_{c,i}(z) \leq \underline{w}_i(z)^2 I \quad \forall z \in \partial\mathbb{D}.$$

Let $z_0 \in \partial\mathbb{D}$, let $i \in \{1, \dots, S + F\}$, and pick a sequence $\{z_{i,k}\}_{k=1}^\infty \subset \partial\mathbb{D}$, converging to z_0 , such that $w_i(z_{i,k}) \rightarrow \underline{w}_i(z_0)$ as $k \rightarrow \infty$. Letting $z = z_{i,k}$ in (18), letting $k \rightarrow \infty$, and invoking continuity of Δ on $\partial\mathbb{D}$, we get

$$\Delta_{c,i}(z_0)^* \Delta_{c,i}(z_0) \leq \underline{w}_i(z_0)^2 I,$$

as claimed. The remaining claims are readily proved. ■

4 Main Results

In the proof of Theorem 2 below we will make use of the following form of Nyquist's criterion, which applies without real-rational assumption.⁵

Lemma 1 *Let $F \in \mathbf{H}_\infty(\mathbb{D}^c)$, with a continuous extension on $\overline{\mathbb{D}^c}$, be such that $(I + F)$ is not invertible in $\mathbf{H}_\infty(\mathbb{D}^c)$. Then there exist a scalar $\alpha \in (0, 1]$ and a point $\tilde{z} \in \partial\mathbb{D}$ such that $\det(I + \alpha F(\tilde{z})) = 0$.*

⁵It is a simplified version of a result given in [T] in the more general case where existence of a continuous extension of F on $\overline{\mathbb{D}^c}$ is not assumed.

Proof: Let G be defined by $G(z) = F(1/z)$. Thus G is analytic and bounded in the interior $\text{int}(\mathbb{D})$ of \mathbb{D} and admits a continuous extension on \mathbb{D} . Since $(I + F)$ is not invertible in $\mathbf{H}_\infty(\mathbb{D}^c)$, $g = \det(I + G)$ cannot be bounded away from 0 on $\text{int}(\mathbb{D})$. Thus there must exist $\hat{z} \in \mathbb{D}$ such that $g(\hat{z}) = 0$. If $\hat{z} \in \partial\mathbb{D}$ the proof is complete, with $\alpha = 1$ and $\tilde{z} = 1/\hat{z}$. Thus assume now that $|\hat{z}| < 1$. Consider the closed path (circle) $\gamma : [-\pi, \pi) \rightarrow \mathbb{D}$ given by $\gamma(\theta) = e^{j\theta}$. Since g is analytic and bounded in $\text{int}(\mathbb{D})$ and has no zero in the range of γ , it follows from Cauchy's Principle of the Argument (see, e.g. [R, Theorem 10.43]) that the origin has a nonzero index with respect to the compound map $g \circ \gamma$ (i.e., $g \circ \gamma$ "encircles" the origin at least once). Consequently if, for every $\alpha \in [0, 1]$, we define $h_\alpha : [0, 2\pi) \rightarrow \mathbb{C}$ by

$$h_\alpha(\theta) = \det(I + \alpha F(\gamma(\theta)))$$

then $h_0 (=1)$ and $h_1 (=g \circ \gamma)$ are not homotopic with respect to the punctured plane. Thus there exists $\alpha \in (0, 1)$ such that the range of h_α contains the origin, i.e., for some $\hat{z}' \in \partial\mathbb{D}$, $\det(I + \alpha G(\hat{z}')) = 0$. The claim follows, with $\tilde{z} = 1/\hat{z}'$. ■

Theorem 2 *Let $P \in \mathcal{P}$ and $W \in \mathcal{W}$. If*

$$\mu(W(z)P(z)) < 1 \quad \forall z \in \partial\mathbb{D}, \tag{19}$$

then $\mathcal{I}(P, \mathbf{B}_W \Delta)$ is robustly stable, and thus so are $\mathcal{I}(P, \mathbf{B}_W \mathbf{R} \Delta)$ and $\mathcal{I}(P, \mathbf{B}_W \mathbf{R} \mathbf{R} \Delta)$. Moreover, suppose that W is bounded. Then, if

$$\sup_{z \in \partial\mathbb{D}} \mu(W(z)P(z)) < 1, \tag{20}$$

then $\mathcal{I}(P, \mathbf{B}_W \Delta)$ is uniformly robustly stable, and thus so are $\mathcal{I}(P, \mathbf{B}_W \mathbf{R} \Delta)$ and $\mathcal{I}(P, \mathbf{B}_W \mathbf{R} \mathbf{R} \Delta)$.

Remark: Note that Theorem 2 applies with no irreducibility assumptions on W . ◇

Proof: Use contradiction to prove the first claim. Thus, let $\Delta \in \mathbf{B}_W \Delta$ be such that $\mathcal{I}(P, \Delta)$ is unstable, i.e., such that $(I + \Delta P)$ is not invertible in $\mathbf{H}_\infty(\mathbb{D}^c)$. Since P and Δ are continuous on $\overline{\mathbb{D}^c}$, it follows from Lemma 1 that there exist $\alpha \in (0, 1]$ and $\hat{z} \in \partial\mathbb{D}$ such that

$$\det(I + \alpha \Delta(\hat{z})P(\hat{z})) = 0.$$

Since $\Delta \in \mathbf{B}_W \Delta$, $\alpha \Delta(\hat{z}) = \hat{\Gamma} W(\hat{z})$ for some $\hat{\Gamma} \in \mathbf{B} \Gamma$. It follows that

$$\mu(W(\hat{z})P(\hat{z})) \geq 1,$$

contradicting (19). Thus the first claim holds.

Concerning the second claim, again proceed by contradiction: Suppose that given any $\epsilon > 0$, there exist $\Delta_\epsilon \in \mathbf{B}_W \mathbf{\Delta}$ and $z_\epsilon \in \partial \mathbb{D}$ such that

$$\underline{\sigma}(I + \Delta_\epsilon(z_\epsilon)P(z_\epsilon)) < \epsilon. \quad (21)$$

Thus there exists a matrix E_ϵ , with $\overline{\sigma}(E_\epsilon) < \epsilon$, such that

$$\underline{\sigma}(I + \Delta_\epsilon(z_\epsilon)P(z_\epsilon)(I + E_\epsilon)^{-1}) = 0,$$

Since

$$\Delta_\epsilon(z_\epsilon)^* \Delta_\epsilon(z_\epsilon) \leq W(z_\epsilon)^2, \quad (22)$$

it follows that

$$\mu(W(z_\epsilon)P(z_\epsilon)(I + E_\epsilon)^{-1}) \geq 1. \quad (23)$$

Since W and P are bounded, there exists a sequence $\{\epsilon_k\}$, with $\epsilon_k \downarrow 0$ as $k \rightarrow \infty$, a point $\tilde{z} \in \partial \mathbb{D}$, and a diagonal matrix \tilde{W} such that $z_{\epsilon_k} \rightarrow \tilde{z}$ and $W(z_{\epsilon_k}) \rightarrow \tilde{W}$ as $k \rightarrow \infty$. Since $\mu(\cdot)$ is upper semicontinuous, it then follows from (23) that

$$\mu(\tilde{W}P(\tilde{z})) \geq 1.$$

If $\mu(\cdot)$ is continuous at $\tilde{W}P(\tilde{z})$ then it follows that, given any $\gamma < 1$ there exists k such that

$$\mu(W(z_{\epsilon_k})P(z_{\epsilon_k})) \geq \gamma,$$

contradicting (20). Thus $\mu(\cdot)$ must be discontinuous at $\tilde{W}P(\tilde{z})$. It follows from [PP, Lemma 5.1] that

$$\mu_{\mathbf{\Gamma}_r}((\tilde{W}P(\tilde{z}))_{\text{rr}}) = \mu(\tilde{W}P(\tilde{z})) \geq 1,$$

where $\mu_{\mathbf{\Gamma}_r}$ denotes the structured singular value with respect to block-structure $\mathbf{\Gamma}_r$ and subscript “rr” refers to the top left $n_r \times n_r$ submatrix. Now,

$$(\tilde{W}P(\tilde{z}))_{\text{rr}} = \tilde{W}_{\text{rr}}P_{\text{rr}}(\tilde{z}) = W_{\text{rr}}(\tilde{z})P_{\text{rr}}(\tilde{z}) = (W(\tilde{z})P(\tilde{z}))_{\text{rr}}$$

where we have used the fact that W_{rr} is constant (see (5)), thus continuous. Thus

$$\mu_{\mathbf{\Gamma}_r}((W(\tilde{z})P(\tilde{z}))_{\text{rr}}) \geq 1,$$

implying that

$$\mu(W(\tilde{z})P(\tilde{z})) \geq 1,$$

a contradiction. ■

Remark: Clearly, if W is unbounded, boundedness of $\|G_\Delta\|_\infty$ over $\mathbf{B}_W\Delta$ does not follow from (20). Note however that, in the 1-block case, (20) implies boundedness of $\|(I + \Delta P)^{-1}\|_\infty$ over $\mathbf{B}_W\Delta$ without boundedness assumption on W . Indeed, μ then becomes the largest singular value $\bar{\sigma}$ and, if (20) holds, then, for some $\gamma < 1$,

$$\bar{\sigma}(\Delta(z)P(z)) \leq \gamma < 1 \quad \forall \Delta \in \mathbf{B}_W\Delta, z \in \partial\mathbb{D},$$

implying that

$$\underline{\sigma}(I + \Delta(z)P(z)) \geq 1 - \gamma > 0 \quad \forall \Delta \in \mathbf{B}_W\Delta, z \in \partial\mathbb{D}.$$

Since, as per the first statement in the theorem, robust stability does hold, it follows that

$$\|(I + \Delta P)^{-1}\|_\infty \leq \frac{1}{1 - \gamma},$$

proving the claim. On the other hand, it may be worth stressing that, in the block-structured case, not even $\|(I + \Delta P)^{-1}\|_\infty$ need be bounded under (20) when W is unbounded. The reason is that, in such case, uncertainties Δ of arbitrarily large size (as allowed by an unbounded W) can leave the system stable while rendering $\|(I + \Delta P)^{-1}\|_\infty$ arbitrarily large. This happens, for example, if the unbounded uncertainty Δ is purely *multiplicative*, so the nominal plant P sees no feedback. Then, stability is no longer an issue; however, $\|(I + \Delta P)^{-1}\|_\infty$ can be made arbitrary large by a suitable choice of Δ . A specific example is illustrated in Figure 3. Here,

$$P = \begin{bmatrix} 0 & 0 \\ 1 & 0 \end{bmatrix},$$

and Δ is a “repeated complex scalar uncertainty”, i.e., in our notation, $n = 2$, $R = 0$, $F = 0$, $S = 1$ and $s_1 = 2$. (Note that similar examples can be constructed with non-repeated uncertainties as well.) Suppose that

$$W(z) = \begin{cases} \max(|\tan(\theta/2)|, 1)I, & z = e^{j\theta}, \theta \in (-\pi, \pi), \\ 0, & z = -1. \end{cases}$$

Then, it is readily checked that W is $\mathbf{H}_\infty(\mathbb{D}^c)$ -irreducible (indeed, real-rational $\mathbf{H}_\infty(\mathbb{D}^c)$ -irreducible), and that $\det(I + \Delta(z)P(z)) = 1$ for all $z \in \partial\mathbb{D}$ and $\Delta \in \mathbf{B}_W\Delta$, so that

$$\sup_{z \in \partial\mathbb{D}} \mu(W(z)P(z)) = 0.$$

Thus, $\mathcal{I}(P, \mathbf{B}_W\Delta)$ is robustly stable. However, consider the system with the uncertainty $\Delta^\epsilon = \delta^\epsilon I$, where

$$\delta^\epsilon(z) = \frac{1}{\sqrt{2}} \frac{2(z+1)}{((1+\epsilon)z + (1-\epsilon))^2},$$

with $\epsilon > 0$. Then it is readily verified that $\Delta^\epsilon \in \mathbf{B}_W \Delta$ for all $\epsilon > 0$. And,

$$\|(I + \Delta^\epsilon P)^{-1}\|_\infty = \left\| \begin{bmatrix} 1 & 0 \\ -\delta^\epsilon & 1 \end{bmatrix} \right\|_\infty > \|\delta^\epsilon\|_\infty = \frac{1}{2\epsilon\sqrt{2(1-\epsilon^2)}},$$

which can be made arbitrarily large by selecting ϵ small enough. ◇

We now turn to necessary conditions. In view of the development thus far, the following question assumes central importance: Under what conditions on W is it the case that violation of (20) implies the existence of a destabilizing $\Delta \in \mathbf{B}_W \Delta$? Also of interest are conditions on W under which, when (20) is violated, there exists a destabilizing Δ in $\mathbf{B}_W \mathbf{R} \Delta$ or $\mathbf{B}_W \mathbf{R} \mathbf{R} \Delta$. We now show that all that is required for the existence of appropriate destabilizing Δ is that W be irreducible in the appropriate sense.

We begin with the following four lemmas, proved in appendices (except for Lemma 4).

Lemma 2 *Let $W \in \mathcal{W}$, W lower semicontinuous, let $P \in \mathcal{P}$, and suppose that*

$$\sup_{z \in \partial \mathbb{D}} \mu(W(z)P(z)) \geq 1. \quad (24)$$

Then, given any $\epsilon > 0$, there exists $\hat{z} \in \partial \mathbb{D}$, $\hat{\Gamma} \in \mathbf{B} \mathbf{\Gamma}$ satisfying

$$\det(I + (1 + \epsilon)\hat{\Gamma}W(\hat{z})P(\hat{z})) = 0 \quad (25)$$

with either $\hat{\Gamma}$ real or $\hat{z} \notin \{-1, 1\}$.

Lemma 3 ⁶ *Let $M \in \mathbb{C}^{n \times n}$ and suppose*

$$\det(I + \Gamma M) = 0$$

for some $\Gamma \in \mathbf{\Gamma}$. Then there exists

$$\Gamma' = \text{diag}(\gamma_1 I_{r_1}, \dots, \gamma_R I_{r_R}, \eta_1 I_{s_1}, \dots, \eta_S I_{s_S}, \Gamma'_1, \dots, \Gamma'_F) \in \mathbf{\Gamma},$$

with $\bar{\sigma}(\Gamma') = \bar{\sigma}(\Gamma)$ and $\text{rank}(\Gamma'_i) \leq 1$, such that

$$\det(I + \Gamma' M) = 0.$$

⁶A proof of this result can be found in [TF], embedded in the proof of Theorem 1. It is reproduced here for the reader's convenience.

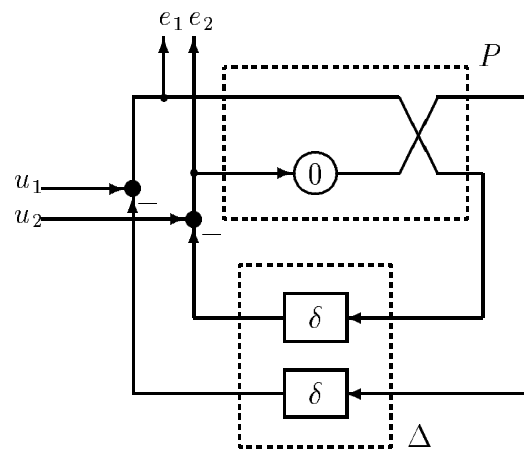

Figure 3: When W is unbounded, uncertainties Δ of arbitrarily large size can leave the system stable while rendering the \mathbf{H}_∞ norm of the transfer function from u to e arbitrarily large.

Lemma 4 Let $\{M_\epsilon \in \mathbb{C}^{n \times n} : \epsilon > 0\}$ be such that

$$\det(I + (1 + \epsilon)M_\epsilon) = 0.$$

Then

$$\lim_{\epsilon \downarrow 0} \underline{\sigma}(I + M_\epsilon) = 0.$$

Lemma 5⁷ Let $\hat{z} \in \partial\mathbb{D} \setminus \{-1, 1\}$, and let

$$\Gamma = \text{diag}(\gamma_1 I_{r_1}, \dots, \gamma_R I_{r_R}, \eta_1 I_{s_1}, \dots, \eta_S I_{s_S}, \Gamma_1, \dots, \Gamma_F) \in \mathbf{B}\Gamma,$$

be such that $\text{rank}(\Gamma_i) \leq 1$. Then there exists $\Delta \in \mathbf{BRR}\Delta$ such that $\Delta(\hat{z}) = \Gamma$.

Theorem 3 Let $P \in \mathcal{P}$ and $W \in \mathcal{W}$. Suppose that

$$\sup_{z \in \partial\mathbb{D}} \mu(W(z)P(z)) \geq 1. \quad (26)$$

Then, if W is $\mathbf{H}_\infty(\mathbb{D}^c)$ -irreducible (respectively, real $\mathbf{H}_\infty(\mathbb{D}^c)$ -irreducible and real-rational $\mathbf{H}_\infty(\mathbb{D}^c)$ -irreducible), then $\mathcal{I}(P, \mathbf{B}_W\Delta)$ (respectively, $\mathcal{I}(P, \mathbf{B}_W\mathbf{R}\Delta)$ and $\mathcal{I}(P, \mathbf{B}_W\mathbf{RR}\Delta)$) is not uniformly robustly stable.

Proof: Suppose that (26) holds. In view of Lemmas 2, 3, and 4, there exist families $\{z_\epsilon \in \partial\mathbb{D} : \epsilon > 0\}$ and $\{\Gamma_\epsilon \in \mathbf{B}\Gamma : \epsilon > 0\}$ such that

$$\lim_{\epsilon \downarrow 0} \underline{\sigma}(I + \Gamma_\epsilon W(z_\epsilon)P(z_\epsilon)) = 0 \quad (27)$$

and, for each $\epsilon > 0$, either (i) Γ_ϵ is real or (ii) $z_\epsilon \notin \{-1, 1\}$ and $\text{rank}(\Gamma_{\epsilon,i}) \leq 1$. Now let $C > 0$. We show that there exists $\hat{\Delta} \in \mathbf{B}_W\Delta$ such that either $(I + \hat{\Delta}P)$ is not invertible in $\mathbf{H}_\infty(\mathbb{D}^c)$ or $\|(I + \hat{\Delta}P)^{-1}\|_\infty > C$, thus proving the claim. Invoking (27), let $\hat{z} \in \partial\mathbb{D}$ and $\hat{\Gamma} \in \mathbf{B}\Gamma$ be such that

$$\underline{\sigma}(I + \hat{\Gamma}W(\hat{z})P(\hat{z})) < 1/(2C).$$

Either $\hat{\Gamma}$ is real or $\hat{z} \notin \{-1, 1\}$ and $\text{rank}(\hat{\Gamma}_i) \leq 1$. If $\hat{\Gamma}$ is real, let $\hat{\Delta} = \hat{\Gamma}$ and the proof of the first statement is complete. Thus, suppose $\hat{z} = e^{j\hat{\theta}} \notin \{-1, 1\}$ and $\text{rank}(\hat{\Gamma}_i) \leq 1$. Without loss of generality suppose that $\hat{\theta} \in (0, \pi)$. To complete the proof we construct a family $\{\Delta_\epsilon : \epsilon \in (0, \max\{\hat{\theta}, \pi - \hat{\theta}\})\}$ in the appropriate ball $(\mathbf{B}_W\Delta, \mathbf{B}_W\mathbf{R}\Delta, \mathbf{B}_W\mathbf{RR}\Delta)$ such that

⁷This result is standard. It can be found in [TF] for the continuous-time case. Some inaccuracies in [TF] have been corrected in the presentation here.

$\Delta_\epsilon(\hat{z})$ converges to $W(\hat{z})\hat{\Gamma}$ as $\epsilon \rightarrow 0$. Thus let $\epsilon \in (0, \max\{\hat{\theta}, \pi - \hat{\theta}\})$. Then, Δ_ϵ will be of the form

$$\Delta_\epsilon(z) = \Phi(z) \text{diag} \left(I_{r_1}, \dots, I_{r_R}, \delta_\epsilon^1(z) I_{s_1}, \dots, \delta_\epsilon^S(z) I_{s_S}, \delta_\epsilon^{S+1}(z) I_{f_1}, \dots, \delta_\epsilon^{S+F}(z) I_{f_F} \right) \tilde{\Delta}_\epsilon(z),$$

where the factors in the right-hand side, all in $\mathbf{\Delta}$, are specified now. Express W as

$$W = \text{diag}(\rho_1 I_{r_1}, \dots, \rho_R I_{r_R}, w_1 I_{s_1}, \dots, w_S I_{s_S}, w_{S+1} I_{f_1}, \dots, w_{S+F} I_{f_F}).$$

First, for every $i \in \{1, \dots, (S+F)\}$ such that $w_i(\hat{z}) = 0$, let δ_ϵ^i be identically zero. For such i , the corresponding entries in the first and third factors are now arbitrary. Now for the first factor. Invoking Lemma 7 (in Appendix A), let

$$\Phi = \text{diag}(\rho_1 I_{r_1}, \dots, \rho_R I_{r_R}, \varphi_1 I_{s_1}, \dots, \varphi_{S+F} I_{f_F}),$$

respectively in $\mathbf{B}_W \mathbf{\Delta}$, $\mathbf{B}_W \mathbf{R} \mathbf{\Delta}$, and $\mathbf{B}_W \mathbf{R} \mathbf{R} \mathbf{\Delta}$, be such that $\varphi_i(\hat{z}) \neq 0$ for every i such that $w_i(\hat{z}) \neq 0$. Concerning the second factor, first let

$$\alpha_\epsilon^i = \min_{\theta \in [\hat{\theta} - \epsilon, \hat{\theta} + \epsilon]} |\varphi_i(e^{j\theta})|^{-1} w_i(e^{j\theta})$$

for every $i \in \{1, \dots, (S+F)\}$ such that $w_i(\hat{z}) \neq 0$. (Reduce the value of ϵ as necessary for φ_i to be invertible in the required range.) Since w_i is lower semicontinuous, the “min” is achieved, and moreover $\alpha_\epsilon^i \geq 1$ whenever $w_i(\hat{z}) \neq 0$. To handle the cases when Δ_ϵ is required to belong to $\mathbf{B}_W \mathbf{R} \mathbf{\Delta}$ or $\mathbf{B}_W \mathbf{R} \mathbf{R} \mathbf{\Delta}$, for every $i \in \{1, \dots, (S+F)\}$ such that $w_i(\hat{z}) \neq 0$, let δ_ϵ^i be the real-rational function in $\mathbf{H}_\infty(\mathbb{D}^c)$ given by $\delta_\epsilon^i(z) = f_\epsilon^i\left(\frac{z-1}{z+1}\right)$, with f_ϵ^i defined by

$$f_\epsilon^i(s) = \frac{a_\epsilon^i}{s^2 + b_\epsilon^i s + c_\epsilon^i} \quad (28)$$

where a_ϵ^i , b_ϵ^i , and c_ϵ^i , with $b_\epsilon^i, c_\epsilon^i > 0$, are real numbers selected in such a way that

$$|\delta_\epsilon^i(\hat{z})| = \alpha_\epsilon^i \geq |\delta_\epsilon^i(z)| \quad \forall z \neq \hat{z}$$

and

$$|\delta_\epsilon^i(z)| \leq 1 \quad \forall z \notin \{e^{j\theta} : \theta \in [-\hat{\theta} - \epsilon, -\hat{\theta} + \epsilon] \cup [\hat{\theta} - \epsilon, \hat{\theta} + \epsilon]\}. \quad (29)$$

In the case when Δ_ϵ is merely required to belong to $\mathbf{B}_W \mathbf{\Delta}$, use the Poisson integral formula in Lemma 6 (in Appendix A) to construct, for all $i \in \{1, \dots, (S+F)\}$ such that $w_i(\hat{z}) \neq 0$, a function δ_ϵ^i in $\mathbf{H}_\infty(\mathbb{D}^c)$, with continuous extension on $\overline{\mathbb{D}^c}$ and whose magnitude is a continuously differentiable function on $\partial\mathbb{D}$, equal to $\left| f_\epsilon^i\left(\frac{z-1}{z+1}\right) \right|$ with f_ϵ^i as above for $z \in \{e^{j\theta} :$

$\theta \in [\hat{\theta} - \epsilon, \hat{\theta} + \epsilon]$, and less than or equal to one for $z \notin \{e^{j\theta} : \theta \in [\hat{\theta} - \epsilon, \hat{\theta} + \epsilon]\}$. Taking into account the fact that, in the cases when Δ_ϵ is required to belong to $\mathbf{B}_W\mathbf{R}\Delta$ or $\mathbf{B}_W\mathbf{RR}\Delta$, the w_i 's are assumed to be conjugate-symmetric, it is readily checked that, in all three cases,

$$|\varphi_i(z)\delta_\epsilon^i(z)| \leq w_i(z) \quad \forall z \in \partial\mathbb{D} \quad i = 1, \dots, (S + F)$$

and

$$|\varphi_i(\hat{z})\delta_\epsilon^i(\hat{z})| \rightarrow w_i(\hat{z}) \quad \text{as } \epsilon \rightarrow 0.$$

Finally, for $i = 1, \dots, (S + F)$, let θ_i^ϵ be the phase of $\varphi_i(\hat{z})\delta_\epsilon^i(\hat{z})$. To complete the proof in all three cases, we invoke Lemma 5 to construct the third factor $\tilde{\Delta}_\epsilon \in \mathbf{BRR}\Delta$ such that

$$\tilde{\Delta}_\epsilon(\hat{z}) = \tilde{\Gamma}_\epsilon = \text{diag}(I_{n_r}, e^{-j\theta_1^\epsilon} I_{s_1}, \dots, e^{-j\theta_{S+F}^\epsilon} I_{s_{S+F}}) \hat{\Gamma}.$$

■

Remark: As noted in Footnote 3, condition (26) *does not* imply the existence of a destabilizing Δ in $\mathbf{B}_W\mathbf{R}\Delta$ (let alone in $\mathbf{B}_W\mathbf{RR}\Delta$), even when when $W(z) = I$ for all $z \in \partial\mathbb{D}$. However, under additional regularity assumptions on W , a destabilizing Δ in $\mathbf{B}_W\Delta$ can be constructed, as can be shown by appropriately modifying the proof of Theorem 3. Continuous differentiability of W is one such regularity assumption. Note that mere continuity of W is not sufficient, as seen from the scalar example $p(z) = 1$, $w(z) = 1/(1 + |\theta|)$ for $z = e^{j\theta}$, $\theta \in [-\pi, \pi)$, where $\mathcal{I}(p, \mathbf{B}_d\Delta)$ is robustly stable since $\mathbf{H}_\infty(\mathbb{C}_+)$ functions that take the value one at $z = 1$ and stay under $w(z)$ on $\partial\mathbb{D}$ must have a discontinuous phase at $z = 1$ and thus cannot be in Δ . On the other hand, whenever the right-hand side in (26) is *strictly* larger than one, then of course, under the respective irreducibility assumptions, destabilizing Δ s do exist in all three balls. (As a matter fact, this follows from Theorem 5 below.) \diamond

Theorems 2 and 3 can be combined to yield a necessary and sufficient condition for uniform robust stability which improves on Theorem 1.

Theorem 4 *Let $P \in \mathcal{P}$, and let $W \in \mathcal{W}$ be bounded. Suppose that W is $\mathbf{H}_\infty(\mathbb{D}^c)$ -irreducible. Then $\mathcal{I}(P, \mathbf{B}_W\Delta)$ is uniformly robustly stable if and only if*

$$\sup_{z \in \partial\mathbb{D}} \mu(W(z)P(z)) < 1. \tag{30}$$

Suppose moreover that W is real $\mathbf{H}_\infty(\mathbb{D}^c)$ -irreducible (respectively, real-rational $\mathbf{H}_\infty(\mathbb{D}^c)$ -irreducible). Then $\mathcal{I}(P, \mathbf{B}_W\mathbf{R}\Delta)$ (respectively, $\mathcal{I}(P, \mathbf{B}_W\mathbf{RR}\Delta)$) is uniformly robustly stable if and only if (30) holds.

A special case of major importance is that where the uncertainty bounds are frequency-independent, i.e., $W = I$. This result is well known but, to our knowledge, neither a precise statement nor a proof are available in the open literature.

Corollary 1 *Given any $P \in \mathcal{P}$, the following are equivalent:*

1. $\mathcal{I}(P, \mathbf{B}\Delta)$ is uniformly robustly stable;
2. $\mathcal{I}(P, \mathbf{BR}\Delta)$ is uniformly robustly stable;
3. $\mathcal{I}(P, \mathbf{BRR}\Delta)$ is uniformly robustly stable;
4. $\sup_{z \in \partial\mathbb{D}} \mu(P(z)) < 1$.

For completeness let us also note (see [TF] and [T, Remark]) that, for $P \in \mathcal{P}$,⁸

$$\sup_{z \in \partial\mathbb{D}} \mu(P(z)) = \sup_{z \in \overline{\mathbb{D}^c}} \mu(P(z))$$

so that a fifth equivalent statement is

$$\sup_{z \in \overline{\mathbb{D}^c}} \mu(P(z)) < 1.$$

It may be somewhat unsatisfying that the necessary and sufficient condition obtained in Theorem 4 requires boundedness of W . This situation however is unavoidable regardless of whether uniform robust stability or mere robust stability is sought. Indeed (i) as shown in the remark following the proof of Theorem 2, boundedness of W is required to guarantee sufficiency of (30) for uniform robust stability and (ii) as shown in the remark following Theorem 3, some regularity (implying boundedness) of W is required to guarantee necessity of (30) for (mere) robust stability (and even then, only for $\mathbf{B}_W\Delta$). We conclude this section by showing that, if “open” uncertainty balls are considered instead, then an appropriate

⁸When $n_r = 0$, $\mu(\cdot)$ is continuous and thus $\overline{\mathbb{D}^c}$ can be replaced by \mathbb{D}^c . This is not so in the general case however. A counterexample (see [TF]) is given by

$$P(z) = \begin{bmatrix} 1 & (z+1)/z \\ -(z+1)/z & 1 \end{bmatrix},$$

with $R = 1$ and $r_1 = 2$ (“repeated-real”). For such a structure $\mu(P(z))$ is the spectral radius of $P(z)$ if $P(z)$ has a real eigenvalue, and 0 otherwise. It is readily checked that $P(z)$ has a real eigenvalue if and only if $(z+1)/z$ is pure imaginary, and the only $z \in \overline{\mathbb{D}^c}$ where this occurs is $z = -1$, which is not in \mathbb{D}^c .

μ condition (nonstrict upper bound) is indeed necessary and sufficient for robust stability, *without* boundedness assumption on W .⁹ Specifically, let $\check{\mathbf{B}}_W\mathbf{\Delta}$ be defined by

$$\check{\mathbf{B}}_W\mathbf{\Delta} = \{\Delta : \Delta \in \xi\mathbf{B}_W\mathbf{\Delta} \text{ for some } \xi < 1\},$$

and similarly define $\check{\mathbf{B}}_W\mathbf{R}\mathbf{\Delta}$ and $\check{\mathbf{B}}_W\mathbf{R}\mathbf{R}\mathbf{\Delta}$ from $\mathbf{B}_W\mathbf{R}\mathbf{\Delta}$ and $\mathbf{B}_W\mathbf{R}\mathbf{R}\mathbf{\Delta}$. Note that when W is $\mathbf{H}_\infty(\mathbb{D}^c)$ -irreducible (respectively, real $\mathbf{H}_\infty(\mathbb{D}^c)$ -irreducible and real-rational $\mathbf{H}_\infty(\mathbb{D}^c)$ -irreducible), then for every $w_i, i = 1, \dots, (S+F)$ that is not identically zero, the corresponding “open” uncertainty sub-ball also contains a nonzero element. We will assume (without loss of generality, in view of Proposition 1) appropriate irreducibility properties for W .

Theorem 5 *Let $P \in \mathcal{P}$, let $W \in \mathcal{W}$, and suppose that W is $\mathbf{H}_\infty(\mathbb{C}_+)$ -irreducible. Then, $\mathcal{I}(P, \check{\mathbf{B}}_W\mathbf{\Delta})$ is robustly stable if and only if*

$$\mu(W(z)P(z)) \leq 1 \quad \forall z \in \partial\mathbb{D}. \quad (31)$$

Suppose moreover that W is real $\mathbf{H}_\infty(\mathbb{C}_+)$ -irreducible (respectively, real-rational $\mathbf{H}_\infty(\mathbb{C}_+)$ -irreducible). Then, $\mathcal{I}(P, \check{\mathbf{B}}_W\mathbf{R}\mathbf{\Delta})$ (respectively, $\mathcal{I}(P, \check{\mathbf{B}}_W\mathbf{R}\mathbf{R}\mathbf{\Delta})$) is robustly stable if and only if (31) holds.

Proof: We use contradiction to prove sufficiency. An argument similar to that used in the proof of the first claim in Theorem 2 shows that, if $\mathcal{I}(P, \Delta)$ is unstable for some $\Delta \in \check{\mathbf{B}}_W\mathbf{\Delta}$, then there exists $\alpha \in (0, 1]$ and $\hat{z} \in \partial\mathbb{D}$ such that

$$\det(I + \alpha\Delta(\hat{z})P(\hat{z})) = 0.$$

Since, for some $\xi < 1$, $\Delta(\hat{z})^*\Delta(\hat{z}) \leq \xi W(\hat{z})^2$, we have that $\alpha\Delta(\hat{z}) = \hat{\Gamma}W(\hat{z})$ for some $\hat{\Gamma} \in \xi\mathbf{B}\mathbf{\Gamma}$ and thus that

$$\mu(W(\hat{z})P(\hat{z})) > 1,$$

a contradiction. We now use contradiction to prove necessity. Thus suppose that, for some $\hat{z} \in \partial\mathbb{D}$,

$$\mu(W(\hat{z})P(\hat{z})) > 1.$$

Then there exists $\hat{\Gamma} \in \mathbf{\Gamma}$, with $\bar{\sigma}(\hat{\Gamma}) < 1$, such that

$$\det(I + \hat{\Gamma}W(\hat{z})P(\hat{z})) = 0.$$

⁹For the special case of frequency-independent uncertainty bound, this result was obtained in [TF] (in the continuous-time case).

It remains to construct $\Delta \in \check{\mathbf{B}}_W \mathbf{\Delta}$ (respectively, $\check{\mathbf{B}}_W \mathbf{R}\mathbf{\Delta}$, $\check{\mathbf{B}}_W \mathbf{R}\mathbf{R}\mathbf{\Delta}$) such that $\Delta(\hat{z}) = \hat{\Gamma}W(\hat{z})$. Let $\gamma > 1$, $\xi < 1$ be such that $\bar{\sigma}(\gamma\hat{\Gamma}) \leq \xi$. Clearly, $\gamma\hat{\Gamma} \in \mathbf{\Gamma}$ and

$$\det(I + (\gamma\hat{\Gamma})(\gamma^{-1}W(\hat{z}))P(\hat{z})) = 0.$$

The remainder of the construction is analogous to, but significantly simpler than, the construction used in the proof of Theorem 3. Thus, Δ will be of the form

$$\Delta(z) = \Phi(z) \text{diag} \left(I_{r_1}, \dots, I_{r_R}, \delta^1(z)I_{s_1}, \dots, \delta^S(z)I_{s_S}, \delta^{S+1}(z)I_{f_1}, \dots, \delta^{S+F}(z)I_{f_F} \right) \tilde{\Delta}(z),$$

where the factors in the right-hand side, all in $\mathbf{\Delta}$, are specified now. Express W as

$$W = \text{diag}(\rho_1 I_{r_1}, \dots, \rho_R I_{r_R}, w_1 I_{s_1}, \dots, w_S I_{s_S}, w_{S+1} I_{f_1}, \dots, w_{S+F} I_{f_F}).$$

First, as in the proof of Theorem 3, for every $i \in \{1, \dots, (S+F)\}$ such that $w_i(\hat{z}) = 0$, let δ_ϵ^i be identically zero; the corresponding entries in the first and third factors are now arbitrary. Now, for the first factor, again following the proof of Theorem 3, in all three cases, let

$$\Phi = \text{diag}(\rho_1 I_{r_1}, \dots, \rho_R I_{r_R}, \varphi_1 I_{s_1}, \dots, \varphi_{S+F} I_{f_F}),$$

respectively in $\check{\mathbf{B}}_W \mathbf{\Delta}$, $\check{\mathbf{B}}_W \mathbf{R}\mathbf{\Delta}$, and $\check{\mathbf{B}}_W \mathbf{R}\mathbf{R}\mathbf{\Delta}$, be such that $\varphi_i(\hat{z}) \neq 0$ for every i for which $w_i(\hat{z}) \neq 0$. Concerning the second factor, first let

$$\alpha^i = |\varphi_i(\hat{z})|^{-1} \gamma^{-1} w_i(\hat{z}),$$

for every $i \in \{1, \dots, (S+F)\}$ such that $w_i(\hat{z}) \neq 0$. Then $\alpha^i \geq 1$ whenever $w_i(\hat{z}) \neq 0$ and, since the w_i 's are lower semicontinuous and since $\gamma > 1$, there is a neighborhood $N(\hat{z})$ of \hat{z} such that, for every $i \in \{1, \dots, (S+F)\}$ such that $w_i(\hat{z}) \neq 0$,

$$\alpha^i \leq |\varphi_i(z)|^{-1} w_i(z) \quad \forall z \in N(\hat{z}) \cap \partial\mathbb{D}.$$

Now pick δ^i exactly like δ_ϵ^i was picked in the proof of Theorem 3 (with α^i replacing α_ϵ^i), except for replacing (29) with

$$|\delta^i(z)| \leq 1 \quad \forall z \text{ such that } \alpha^i > |\varphi_i(z)|^{-1} w_i(z).$$

Finally, $\tilde{\Delta} \in \xi \mathbf{B}_W \mathbf{R}\mathbf{R}\mathbf{\Delta}$ is constructed as in the proof of Theorem 3, with $\gamma\hat{\Gamma}$ replacing $\hat{\Gamma}$.

■

In the case of frequency-independent bounds, the discrete-time counterpart of the result proved in [TF] is recovered.

Corollary 2 *Given any $P \in \mathcal{P}$, the following are equivalent:*

1. $\mathcal{I}(P, \check{\mathbf{B}}\Delta)$ is robustly stable;
2. $\mathcal{I}(P, \check{\mathbf{B}}\mathbf{R}\Delta)$ is robustly stable;
3. $\mathcal{I}(P, \check{\mathbf{B}}\mathbf{R}\mathbf{R}\Delta)$ is robustly stable;
4. $\mu(P(z)) \leq 1 \quad \forall z \in \partial\mathbb{D}$.

With reference to the comment following Corollary 1, a fifth equivalent statement is

$$\mu(P(z)) \leq 1 \quad \forall z \in \overline{\mathbb{D}^c}.$$

5 Synopsis of the continuous-time case

We briefly present the continuous-time version of the results obtained in §4 here. Some notation first. Let \mathbb{R}_+ be the set of nonnegative real numbers. Let \mathbb{C}_+ be the closed right half of the complex plane. Let $\mathbb{R}_e = \mathbb{R} \cup \{\infty\}$ be the one-point compactification of \mathbb{R} .

$\mathbf{H}_\infty(\mathbb{C}_+)$ denotes the set of functions that are bounded and analytic over \mathbb{C}_+ . For compactness of notation, we will also use $\mathbf{H}_\infty(\mathbb{C}_+)$ to denote matrix-valued functions, whose entries are in $\mathbf{H}_\infty(\mathbb{C}_+)$. With $\mathbf{\Gamma}_r$ and $\mathbf{\Gamma}_c$ as defined in (1)–(3), let $\mathbf{\Delta}_c$ be defined by

$$\mathbf{\Delta}_c = \{\Delta_c \in \mathbf{H}_\infty(\mathbb{C}_+) : \Delta_c(s) \in \mathbf{\Gamma}_c \forall s \in \mathbb{C}_+, \Delta_c \text{ admits a continuous extension on } \overline{\mathbb{C}_+} \cup \{\infty\}\},$$

and let $\mathbf{\Delta}$ be defined as in the discrete-time case by

$$\mathbf{\Delta} = \{\Delta : \Delta = \text{diag}(\Delta_r, \Delta_c), \quad \Delta_r \in \mathbf{\Gamma}_r, \Delta_c \in \mathbf{\Delta}_c\}.$$

We next define

$$\mathcal{W}_{\text{CT}} = \left\{ W = \text{diag}(\rho_1 I_{r_1}, \dots, \rho_R I_{r_R}, w_1 I_{s_1}, \dots, w_S I_{s_S}, w_{S+1} I_{f_1}, \dots, w_{S+F} I_{f_F}) \text{ for } \right. \\ \left. W : \text{some nonnegative real numbers } \rho_i, i = 1, \dots, R \text{ and some functions } \right. \\ \left. w_i : \mathbb{R}_e \rightarrow \mathbb{R}_+, i = 1, \dots, (S+F) \right\}, \quad (32)$$

and \mathcal{P}_{CT} as

$$\mathcal{P}_{\text{CT}} = \{P \in \mathbf{H}_\infty(\mathbb{C}_+) : P \text{ has a continuous extension on } \overline{\mathbb{C}_+} \cup \{\infty\}\}.$$

Given $W \in \mathcal{W}_{\text{CT}}$, define

$$\mathbf{B}_W \mathbf{\Delta} = \left\{ \Delta \in \mathbf{\Delta} : \Delta(j\omega)^* \Delta(j\omega) \leq W(\omega)^2 \text{ for all } \omega \in \mathbb{R}_e \right\}, \quad (33)$$

$$\mathbf{B}_W \mathbf{R} \Delta = \{\Delta \in \mathbf{B}_W \Delta : \Delta \text{ is real on the real axis}\},$$

and

$$\mathbf{B}_W \mathbf{R} \mathbf{R} \Delta = \{\Delta \in \mathbf{B}_W \Delta : \Delta \text{ is real-rational}\}.$$

For the case when $W(\omega) = I$ for all $\omega \in \mathbb{R}_e$, these balls are again denoted by $\mathbf{B} \Delta$, $\mathbf{B} \mathbf{R} \Delta$, and $\mathbf{B} \mathbf{R} \mathbf{R} \Delta$, respectively.

We then have the following theorems.

Theorem 6 *Let $P \in \mathcal{P}_{\text{CT}}$ and $W \in \mathcal{W}_{\text{CT}}$. If*

$$\mu(W(\omega)P(j\omega)) < 1 \quad \forall \omega \in \mathbb{R}_e, \quad (34)$$

then $\mathcal{I}(P, \mathbf{B}_W \Delta)$ is robustly stable and thus so are $\mathcal{I}(P, \mathbf{B}_W \mathbf{R} \Delta)$ and $\mathcal{I}(P, \mathbf{B}_W \mathbf{R} \mathbf{R} \Delta)$. Moreover, suppose that W is bounded. Then, if

$$\sup_{\omega \in \mathbb{R}_e} \mu(W(\omega)P(j\omega)) < 1, \quad (35)$$

then $\mathcal{I}(P, \mathbf{B}_W \Delta)$ is uniformly robustly stable and thus so are $\mathcal{I}(P, \mathbf{B}_W \mathbf{R} \Delta)$ and $\mathcal{I}(P, \mathbf{B}_W \mathbf{R} \mathbf{R} \Delta)$.

Note that whenever $n_r = 0$, \mathbb{R}_e in (35) can equivalently be replaced by \mathbb{R} (even if W is discontinuous at ∞ : use Lemma 9).

In parallel with the discrete-time case, we will say that W is $\mathbf{H}_\infty(\mathbb{C}_+)$ -irreducible if every $w_i, i = 1, \dots, (S+F)$ is lower semicontinuous on \mathbb{R}_e , and for every $w_i, i = 1, \dots, (S+F)$ that is not identically zero, the corresponding uncertainty sub-ball contains a nonzero element, i.e., there exists some nonzero $\Delta_{c,i} \in \mathbf{H}_\infty(\mathbb{C}_+)$, continuous on $\overline{\mathbb{C}_+} \cup \{\infty\}$, such that

$$\Delta_{c,i}(j\omega)^* \Delta_{c,i}(j\omega) \leq w_i(\omega)^2 I \quad \forall \omega \in \mathbb{R}_e. \quad (36)$$

We will say W is *real $\mathbf{H}_\infty(\mathbb{C}_+)$ -irreducible* if it is $\mathbf{H}_\infty(\mathbb{C}_+)$ -irreducible, and W is even. We will say W is *real-rational $\mathbf{H}_\infty(\mathbb{C}_+)$ -irreducible* if it is real $\mathbf{H}_\infty(\mathbb{C}_+)$ -irreducible, and for every w_i that is not identically zero, there exists a nonzero real-rational $\Delta_{c,i}$ such that (36) holds.

Remark: Similarly to the discrete-time case, when the w_i s are lower semicontinuous on \mathbb{R}_e , $\mathbf{H}_\infty(\mathbb{C}_+)$ -irreducibility amounts to a certain log-integrability condition on those w_i s that are not identically zero. Specifically, in the continuous-time case, $\min\{0, (\log w_i(\omega))/(1 + \omega^2)\}$ must be integrable on the real line. (To see this, make use of a bilinear transformation between \mathbb{D}^c and \mathbb{C}_+ .)

◇

Theorem 7 Let $P \in \mathcal{P}_{\text{CT}}$ and $W \in \mathcal{W}_{\text{CT}}$. Suppose that

$$\sup_{\omega \in \mathbb{R}_e} \mu(W(\omega)P(j\omega)) \geq 1. \quad (37)$$

Then, if W is $\mathbf{H}_\infty(\mathbb{C}_+)$ -irreducible (respectively, real $\mathbf{H}_\infty(\mathbb{C}_+)$ -irreducible and real-rational $\mathbf{H}_\infty(\mathbb{C}_+)$ -irreducible), then $\mathcal{I}(P, \mathbf{B}_W \Delta)$ (respectively, $\mathcal{I}(P, \mathbf{B}_W \mathbf{R} \Delta)$ and $\mathcal{I}(P, \mathbf{B}_W \mathbf{R} \mathbf{R} \Delta)$) is not uniformly robustly stable.

Note that the theorem remains true (but is generally weaker) if, in (37), \mathbb{R}_e is replaced by \mathbb{R} . Again, when $n_r = 0$, such a change leaves (37) unaffected.

Theorems 6 and 7 yield the following necessary and sufficient condition, which also holds with \mathbb{R}_e replaced with \mathbb{R} whenever $n_r = 0$.

Theorem 8 Let $P \in \mathcal{P}_{\text{CT}}$, let $W \in \mathcal{W}_{\text{CT}}$, bounded, and suppose W is $\mathbf{H}_\infty(\mathbb{C}_+)$ -irreducible (respectively, real $\mathbf{H}_\infty(\mathbb{C}_+)$ -irreducible, real-rational $\mathbf{H}_\infty(\mathbb{C}_+)$ -irreducible). Then, $\mathcal{I}(P, \mathbf{B}_W \Delta)$ (respectively, $\mathcal{I}(P, \mathbf{B}_W \mathbf{R} \Delta)$, $\mathcal{I}(P, \mathbf{B}_W \mathbf{R} \mathbf{R} \Delta)$) is uniformly robustly stable if and only if

$$\sup_{\omega \in \mathbb{R}_e} \mu(W(\omega)P(j\omega)) < 1. \quad (38)$$

Corollary 3 Given any $P \in \mathcal{P}_{\text{CT}}$, the following are equivalent:

1. $\mathcal{I}(P, \mathbf{B} \Delta)$ is uniformly robustly stable;
2. $\mathcal{I}(P, \mathbf{B} \mathbf{R} \Delta)$ is uniformly robustly stable;
3. $\mathcal{I}(P, \mathbf{B} \mathbf{R} \mathbf{R} \Delta)$ is uniformly robustly stable;
4. $\sup_{\omega \in \mathbb{R}_e} \mu(P(j\omega)) < 1$.

A fifth equivalent statement is

$$\sup_{s \in \overline{\mathbb{C}_+} \cup \{\infty\}} \mu(P(s)) < 1.$$

Finally, as in the discrete-time case, we give a necessary and sufficient condition for robust stability that holds without boundedness assumption on W . We define

$$\check{\mathbf{B}}_W \Delta = \{\Delta : \Delta \in \xi \mathbf{B}_D \Delta \text{ for some } \xi < 1\},$$

and $\check{\mathbf{B}}_W \mathbf{R} \Delta$ and $\check{\mathbf{B}}_W \mathbf{R} \mathbf{R} \Delta$ similarly.

Theorem 9 *Let $P \in \mathcal{P}_{\text{CT}}$, let $W \in \mathcal{W}_{\text{CT}}$, and suppose W is $\mathbf{H}_{\infty}(\mathbb{C}_+)$ -irreducible (respectively, real $\mathbf{H}_{\infty}(\mathbb{C}_+)$ -irreducible, real-rational $\mathbf{H}_{\infty}(\mathbb{C}_+)$ -irreducible). Then, $\mathcal{I}(P, \check{\mathbf{B}}_W \Delta)$ (respectively, $\mathcal{I}(P, \check{\mathbf{B}}_W \mathbf{R} \Delta)$, $\mathcal{I}(P, \check{\mathbf{B}}_W \mathbf{R} \mathbf{R} \Delta)$) is robustly stable if and only if*

$$\mu(W(j\omega)P(j\omega)) \leq 1 \quad \forall \omega \in \mathbb{R}_e. \quad (39)$$

Corollary 4 [TF] *Given any $P \in \mathcal{P}_{\text{CT}}$, the following are equivalent:*

1. $\mathcal{I}(P, \check{\mathbf{B}} \Delta)$ is robustly stable;
2. $\mathcal{I}(P, \check{\mathbf{B}} \mathbf{R} \Delta)$ is robustly stable;
3. $\mathcal{I}(P, \check{\mathbf{B}} \mathbf{R} \mathbf{R} \Delta)$ is robustly stable;
4. $\mu(P(j\omega)) \leq 1 \quad \forall \omega \in \mathbb{R}_e$.

A fifth equivalent statement is

$$\mu(P(s)) \leq 1 \quad \forall s \in \overline{\mathbb{C}_+} \cup \{\infty\}.$$

6 Concluding remarks

Both necessary conditions and sufficient conditions have been obtained for (uniform) robust stability in the presence of structured uncertainty with frequency-dependent bounds. Two necessary and sufficient conditions were also obtained. For the first one (uniform robust stability) the frequency bound is required to be bounded, and it was shown that the result does not hold without such condition. The second one (robust stability over an “open” ball) holds with essentially no assumption on the uncertainty ball: indeed, irreducibility is a property not of the uncertainty set, but of its representation. Thus our goal of providing small- μ theorems that hold under “weak” assumptions is achieved.

Acknowledgment. The authors wish to thank Carlos Berenstein, as well as Dan Luecking and other contributors to `sci.math.research`, for their valuable help in connection with Lemmas 6 and 7.

References

- [D] J. Doyle, Analysis of feedback systems with structured uncertainties, *IEEE Proc.*, 129-D (1982), 242–250.

- [G] J. B. Garnett, *Bounded Analytic Functions*, Academic Press, New York, 1981.
- [KGP] P. P. Khargonekar, T. T. Georgiou, and A. M. Pascoal, On the robust stabilization of time-invariant plants with unstructured uncertainty, *IEEE Trans. Automat. Contr.*, 32 (1987), 201–207.
- [K] P. Koosis, *Introduction to \mathbf{H}_p spaces*, Cambridge University Press, Cambridge, 1980.
- [L] W. S. Levine, editor, *The Control Handbook*, CRC Press, Boca Raton, Florida, 1996.
- [PD] A. Packard and J. Doyle, The complex structured singular value, *Automatica*, 29 (1993), 71–109.
- [PP] A. Packard and P. Pandey, Continuity properties of the real/complex structured singular value, *IEEE Trans. Automat. Contr.*, 38 (1993), 415–428.
- [R] W. Rudin, *Real and Complex Analysis*, McGraw-Hill, New York, 1974.
- [S] M. G. Safonov, Stability margins of diagonally perturbed multivariable feedback systems, *IEE Proc.*, 129-D (1982), 251–256.
- [T] A. L. Tits, The small μ theorem without real-rational assumption, *Proceedings of the American Control Conference*, Seattle, Washington, June 1995, 2870–2872.
- [TF] A. L. Tits and M.K.H. Fan, On the Small- μ Theorem, *Automatica*, 31 (1995), 1199–1201.
- [ZD] K. Zhou with J. C. Doyle, *Essentials of Robust Control*, Prentice Hall, New Jersey, 1998.
- [ZDG] K. Zhou with J. Doyle and K. Glover, *Robust and Optimal Control*, Prentice Hall, New Jersey, 1996.

Appendix A: Some results from complex analysis

Lemma 6 Let $w : \partial\mathbb{D} \rightarrow \mathbb{R}_+$ be a continuously differentiable function, with $\log w$ being integrable over $\partial\mathbb{D}$. Define the function $\psi : \mathbb{D}^c \rightarrow \mathbb{C}$ by

$$\psi(z) = \frac{1}{2\pi} \int_0^{2\pi} \log w(e^{-j\theta}) \frac{z + e^{-j\theta}}{z - e^{-j\theta}} d\theta. \quad (40)$$

Let $\phi(z) = e^{\psi(z)}$. Then:

- $\phi \in \mathbf{H}_\infty(\mathbb{D}^c)$, and admits a continuous extension on $\overline{\mathbb{D}^c}$.
- $|\phi(re^{j\theta})|$ converges to $w(e^{j\theta})$ as $r \downarrow 1$.

Moreover:

- If w is conjugate-symmetric, i.e., $w(z^*) = w(z)$ on $\partial\mathbb{D}$, then ϕ is real on the real axis.
- If w is bounded away from zero over $\partial\mathbb{D}$, $\phi^{-1} \in \mathbf{H}_\infty(\mathbb{D}^c)$.

Proof: This lemma represents an application of the standard Poisson integral formula (see for example, [G, Ch. I, §3]) to construct a function ψ , analytic in \mathbb{D}^c , such that $\operatorname{Re} \psi(re^{j\theta}) \rightarrow \log w$ as $r \downarrow 1$. Continuity of ψ (and consequently ϕ) over $\overline{\mathbb{D}^c}$ results from the fact that $\operatorname{Im} \psi(re^{j\theta}) \rightarrow \tilde{w}$ as $r \downarrow 1$, where $\tilde{w} : \partial\mathbb{D} \rightarrow \mathbb{R}$ is a continuous function (this is guaranteed by the continuity of the derivative of w ; see for example, [K, pp. 25–26]).

Next, if w is conjugate-symmetric, it is easily verified that $\psi(z)^* = \psi(z)$, whenever $z = z^*$, so that ψ , and hence ϕ are real-valued on the real axis. Finally, when w is bounded away from zero over $\partial\mathbb{D}$, ϕ^{-1} is analytic in \mathbb{D}^c , and bounded over $\overline{\mathbb{D}^c}$, so that $\phi^{-1} \in \mathbf{H}_\infty(\mathbb{D}^c)$. ■

We next state a “nontriviality” condition for the set of uncertainties.

Lemma 7 Suppose that $w : \partial\mathbb{D} \rightarrow \mathbb{R}_+$ is lower semicontinuous. Let

$$\mathbf{B}_w \mathbf{\Delta} = \left\{ \Delta \in \mathbf{H}_\infty(\mathbb{D}^c) : \begin{array}{l} \Delta \text{ has a continuous extension on } \overline{\mathbb{D}^c} \\ \Delta(z)^* \Delta(z) \leq w^2 I \text{ for all } z \in \partial\mathbb{D}, \end{array} \right\}$$

and

$$\mathbf{B}_w \mathbf{R}\mathbf{\Delta} = \{ \Delta \in \mathbf{B}_w \mathbf{\Delta} : \Delta \text{ is real on the real axis} \}.$$

Then the following conditions are equivalent:

1. $\mathbf{B}_w \mathbf{\Delta}$ contains an element besides 0.
2. $\mathbf{B}_w \mathbf{R}\mathbf{\Delta}$ contains an element besides 0.
3. $\min(0, \log w)$ is integrable over $\partial\mathbb{D}$.

Moreover, when any of these conditions hold, there exists an element of the form ϕI in $\mathbf{B}_w \mathbf{R}\mathbf{\Delta}$, with $\phi : \mathbb{C} \rightarrow \mathbb{C}$, satisfying for $z \in \partial\mathbb{D}$, $|\phi(z)| > 0$ whenever $w(z) > 0$.

Proof: Clearly, (2) implies (1). We now show that (1) implies (3). Suppose some nonzero $\Delta \in \mathbf{B}_w \mathbf{\Delta}$. Let δ be some nonzero entry of Δ . Then, $\log |\delta|$ is integrable over $\partial\mathbb{D}$ (see for example, [G, Ch. II, Thm 4.1]). Since w is measurable (being lower semicontinuous) and since $w(z) \geq |\delta(z)|$ for $z \in \partial\mathbb{D}$, $\min(0, \log w)$ is integrable over $\partial\mathbb{D}$ as well.

Next, we show that (3) implies (2). Suppose that $\min(0, \log w)$ is integrable over $\partial\mathbb{D}$. Define \hat{w} by $\hat{w}(z) = \min(w(z), w(z^*))$. Then, $\min(1, \hat{w})$ is lower semicontinuous and log-integrable over $\partial\mathbb{D}$, so that it is a limit from below of continuous functions which are log-integrable over $\partial\mathbb{D}$. Let $g : \partial\mathbb{D} \rightarrow \mathbb{R}_+$ be a continuous function, that is conjugate-symmetric, bounded above by $\min(1, \hat{w})$, with g being log-integrable. Then g can be uniformly approximated from below by a continuously differentiable log-integrable function $h : \partial\mathbb{D} \rightarrow \mathbb{R}_+$, also conjugate-symmetric. Then, a function $\phi \in \mathbf{H}_\infty(\mathbb{D}^c)$ can be constructed using Lemma 6 with a continuous extension over $\overline{\mathbb{D}^c}$, real on the real axis, and with $|\phi(z)| = h(z)$ for all $z \in \partial\mathbb{D}$. Clearly, $\phi I \in \mathbf{B}_w \mathbf{R} \mathbf{\Delta}$.

Finally, for every z such that $w(z) > 0$, the functions g and h in the above construction can be chosen to satisfy $g(z) > 0$ and $h(z) > 0$ respectively, and the last statement of the lemma follows. \blacksquare

Appendix B. Proof of Lemma 2

The following two lemmas will be used. The first lemma is a direct consequence of a result of Packard and Pandey [PP, Lemma 5.1]. It generalizes Lemma 1 of [TF].

Lemma 8 *Let $M \in \mathbb{C}^{n \times n}$ be such that $\mu(M) > 0$ and μ is discontinuous at M . Then there exists a real matrix $\Gamma \in \mathbf{\Gamma}$ such that $\bar{\sigma}(\Gamma) = 1/\mu(M)$ and $\det(I + \Gamma M) = 0$.*

Proof: Let $M_{\text{rr}} \in \mathbb{C}^{n_r \times n_r}$ be the top left submatrix of M . From Lemma 5.1 in [PP], it follows that discontinuity of μ at M implies that $\mu_{\mathbf{\Gamma}_r}(M_{\text{rr}}) = \mu(M)$, where $\mu_{\mathbf{\Gamma}_r}(M_{\text{rr}})$ denotes the structured singular value of M_{rr} with respect to block structure $\mathbf{\Gamma}_r$. Since $\mu(M) > 0$, there exists $\Gamma_r \in \mathbf{\Gamma}_r$ with $\bar{\sigma}(\Gamma_r) = 1/\mu(M)$ such that $\det(I + \Gamma_r M_{\text{rr}}) = 0$. It is readily checked that the matrix $\Gamma \in \mathbf{\Gamma}$ defined by $\Gamma = \text{diag}\{\Gamma_r, 0_{n_c}\}$ satisfies the required properties. \blacksquare

Lemma 9 *Let $M \in \mathbb{C}^{n \times n}$ and let $\alpha_i \geq 1$, $i = 1, \dots, n$. Then, given any block structure $\mathbf{\Gamma}$,*

$$\mu(\text{diag}(\alpha_i)M) \geq \mu(M).$$

Proof: If $\mu(M) = 0$, the result holds trivially. Thus, suppose $\mu(M) > 0$, and let $\Gamma \in \mathbf{\Gamma}$, with $\bar{\sigma}(\Gamma) = 1/\mu(M)$ satisfy $\det(I + \Gamma M) = 0$. Let $\Gamma' = \Gamma \text{diag}(\alpha_i)^{-1}$. Since $\alpha_i \geq 1$ for all i it follows that $\bar{\sigma}(\Gamma') \leq \bar{\sigma}(\Gamma)$. Moreover,

$$\det(I + \Gamma' \text{diag}(\alpha_i)M) = \det(I + \Gamma M) = 0.$$

The claim follows. ■

Proof of Lemma 2 Let $z' \in \partial\mathbb{D}$ such that

$$\mu(W(z')P(z')) \geq \frac{1}{\sqrt[3]{1+\epsilon}}.$$

There are two cases: either $\mu(\cdot)$ is continuous at $W(z')P(z')$ or it is discontinuous at that point. First suppose it is discontinuous. In that case, it follows from Lemma 8 that there is a *real* $\Gamma' \in \mathbf{\Gamma}$, with $\bar{\sigma}(\Gamma') \leq \sqrt[3]{1+\epsilon}$ such that

$$\det(I + \Gamma' W(z')P(z')) = 0$$

i.e., (25) holds with $\hat{\Gamma} = \frac{1}{1+\epsilon}\Gamma' \in \mathbf{B}\mathbf{\Gamma}$, real, and $\hat{z} = z'$. Suppose now that $\mu(\cdot)$ is continuous at $W(z')P(z')$. If $z' \notin \{-1, 1\}$, then the claim follows directly from the definition of μ , with $\hat{z} = z'$. Thus suppose that $z' = 1$ (the proof is similar when $z' = -1$), i.e.,

$$\mu(W(1)P(1)) \geq \frac{1}{\sqrt[3]{1+\epsilon}}.$$

By continuity, there exists $\theta' \in (0, \pi)$ such that

$$\mu(W(1)P(e^{j\theta})) \geq \frac{1}{(1+\epsilon)^{2/3}} \quad \forall \theta \in [0, \theta'],$$

implying, since μ is positively homogeneous, that

$$\mu\left(\frac{1}{\sqrt[3]{1+\epsilon}}W(1)P(e^{j\theta})\right) \geq \frac{1}{(1+\epsilon)} \quad \forall \theta \in [0, \theta').$$

Now, since the (diagonal) entries w_i of W are lower semicontinuous, there exists $\hat{\theta} \in (0, \theta')$ such that, for all i ,

$$w_i(e^{j\hat{\theta}}) \geq \frac{1}{\sqrt[3]{1+\epsilon}}w_i(1).$$

It follows from Lemma 9 that

$$\mu(W(e^{j\hat{\theta}})P(e^{j\hat{\theta}})) \geq \frac{1}{(1+\epsilon)}.$$

The claim follows readily, with $\hat{z} = e^{j\hat{\theta}}$.

Appendix C. Proof of Lemma 3

Express Γ as

$$\Gamma = \text{diag}(\gamma_1 I_{r_1}, \dots, \gamma_R I_{r_R}, \eta_1 I_{s_1}, \dots, \eta_S I_{s_S}, \Gamma_1, \dots, \Gamma_F),$$

and let $\|\cdot\|$ denote the Euclidean norm in \mathbb{C}^n . Let $u \in \mathbb{C}^n$, with $\|u\| = 1$, be such that

$$(I + M\Gamma)u = 0.$$

Express u as $[\hat{u}^T, u_1^T, \dots, u_F^T]^T$, with $\hat{u} \in \mathbb{C}^{n_r + \sum s_i}$ and $u_i \in \mathbb{C}^{f_i}$, and let

$$\Gamma' = \text{diag}(\gamma_1 I_{r_1}, \dots, \gamma_R I_{r_R}, \eta_1 I_{s_1}, \dots, \eta_S I_{s_S}, \Gamma'_1, \dots, \Gamma'_F)$$

with, for $i = 1, \dots, F$,

$$\Gamma'_i = \begin{cases} \Gamma_i u_i u_i^* / \|u_i\|^2 & \text{if } \|u_i\| \neq 0, \\ 0 & \text{otherwise.} \end{cases}$$

Then clearly $\bar{\sigma}(\Gamma') = \bar{\sigma}(\Gamma)$ and, for $i = 1, \dots, F$, $\text{rank}(\Gamma'_i) \leq 1$. Moreover

$$(I + M\Gamma')u = u + M\Gamma u = (I + M\Gamma)u = 0,$$

and thus $\det(I + M\Gamma') = 0$, proving our claim.

Appendix D. Proof of Lemma 5

For $i = 1, \dots, S$, let δ_i be an all-pass, stable transfer function defined by

$$\delta_i(z) = a_i \frac{1 + \alpha_i z}{z + \alpha_i}$$

where $a_i \in [-1, 1]$ and $\alpha_i \in (-1, 1]$ are such that $\delta_i(\hat{z}) = \eta_i$. It is readily checked that, since $\hat{z} \notin \{-1, 1\}$, this is always possible. Next, for $i \in \{1, \dots, F\}$, let $\sigma_i v_i w_i^*$ ($\sigma_i \in [0, 1]$) be the singular value decomposition of Γ_i and let v_i^j and w_i^j be the j th entries of v_i and w_i , respectively. Let $x_i = [x_i^1, \dots, x_i^{f_i}]^T$ and $y_i = [y_i^1, \dots, y_i^{f_i}]^T$ be real-rational vector functions, with x_i analytic and bounded in \mathbb{D}^c and y_i analytic and bounded in the interior of \mathbb{D} , defined by

$$x_i^j(z) = a_{ij} \frac{1 + \alpha_{ij} z}{z + \alpha_{ij}}, \quad y_i^j(z) = b_{ij} \frac{z + \beta_{ij}}{1 + \beta_{ij} z}$$

where $a_{ij}, b_{ij} \in [-1, 1]$, $\alpha_{ij}, \beta_{ij} \in (-1, 1]$ are such that

$$x_i^j(\hat{z}) = v_i^j, \quad y_i^j(\hat{z}) = w_i^j, \quad j = 1, \dots, f_i$$

Let $\Delta_i(z) = \sigma_i x_i(z) y_i (1/z)^T$. Finally, let

$$\Delta(z) = \text{diag}(\gamma_1 I_{r_1}, \dots, \gamma_R I_{r_R}, \delta_1(z) I_{s_1}, \dots, \delta_S(z) I_{s_S}, \Delta_1(z), \dots, \Delta_F(z)).$$

Clearly, $\Delta \in \mathbf{BRR}\mathbf{\Delta}$ and $\Delta(\hat{z}) = \Gamma$.

List of Figures

| | | |
|---|--|----|
| 1 | The P - Δ interconnection modeling an uncertain system. | 2 |
| 2 | The \tilde{P} - $\tilde{\Delta}$ interconnection. $\mathcal{I}(P, \Delta)$ is stable if and only if $\mathcal{I}(\tilde{P}, \tilde{\Delta})$ is. | 7 |
| 3 | When W is unbounded, uncertainties Δ of arbitrarily large size can leave the system stable while rendering the \mathbf{H}_∞ norm of the transfer function from u to e arbitrarily large. | 15 |